

Experimenting Chaos with Chaotic Training Boards

Recai KILIÇ, and Nimet KORKMAZ

Department of Electrical & Electronics Engineering, Erciyes University, Kayseri, Turkey
(E-mail: kilic@erciyes.edu.tr; nimetdahasert@erciyes.edu.tr)

Abstract. Chaos Training Boards, consist of four sets, have been designed and implemented in a systematic way for experimenting chaos and chaotic dynamics. After a long design period and primitive prototypes, we completed final versions of the training boards. In this study, it is aimed to introduce these training boards, their design methodology and experimental studies with the boards. Thanks to these boards, the mainly chaotic oscillator systems including Chua's oscillators (Chua's, MLC and Mixed-Mode Chaotic circuits), Lorenz-Family Systems, Chaotic Systems based on Jerk Equations, Rössler oscillator, Chaotic Wien Bridge oscillator, Chaotic Colpitts oscillator, RLD oscillator and Transistor based nonautonomous chaotic oscillator can be investigated experimentally, and these laboratory tools provide new educational insights for practicing chaotic dynamics in a systematic way in science and engineering programs.

Keywords: Chaos, Chaotic Circuits and Systems, Training Boards, Laboratory Tools.

1 Introduction

In addition to the theoretical and practical studies on chaotic circuits and systems, the laboratory tools designed in a systematic way are required for studying and introducing chaotic circuits and systems in graduate and undergraduate research and education programs. To meet this requirement, we had designed and implemented laboratory tools, namely "Chaos Training Boards" and we had introduced these laboratory apparatus in different scientific platforms [1, 2].

Chaos Training Board-I, shown in Fig.1a, consists of eight pre-constructed circuit blocks. The core of training board-I is Mixed-Mode Chaotic Circuit (MMCC) [3] which offers an excellent educational circuit model for studying and practical experimenting chaos and chaotic dynamics. MMCC operates either in the chaotic regime determined by autonomous circuit part, or in the chaotic regime determined by nonautonomous circuit part depending on static switching, and it is capable to operate in mixed-mode which includes both autonomous and nonautonomous regimes depending on dynamic switching. As a result of being very flexible and versatile design methodology of training board, the user can configure the main chaotic circuit (MMCC) with alternative nonlinear resistor structures and inductorless forms [4].



Chaos Training Board-II is shown in Fig. 1b. It presents a collection of five chaotic circuits including chaotic Colpitts oscillator, RLD circuit, Rossler circuit, Wien-bridge based circuit and transistor based nonautonomous circuit. These circuits are selected for illustrating a variety of ways in which chaos can arise in simple analog oscillator structures containing active elements, specifically BJT and Op-amp [5, 6].

Chaos Training Board-III, shown in Fig.1c, is based on a common chaotic system using Jerk equations. It can be configured with three optional nonlinear function blocks on the board. Periodic and chaotic dynamics can be easily observed via this training board. And also, this dynamical system has a wide operating frequency and its frequency changes can be configured via Chaos Training Board-III [7, 8].

Chaos Training Board-IV in Fig.1d consists of a comprehensive combination of three chaotic systems based on Lorenz family [9-11]. In the literature, there are several chaotic systems similar to Lorenz system, but their chaotic dynamics are different. Thus, they are referred as Lorenz system family. Chaotic Training Board-IV has been designed by utilizing these similarities.

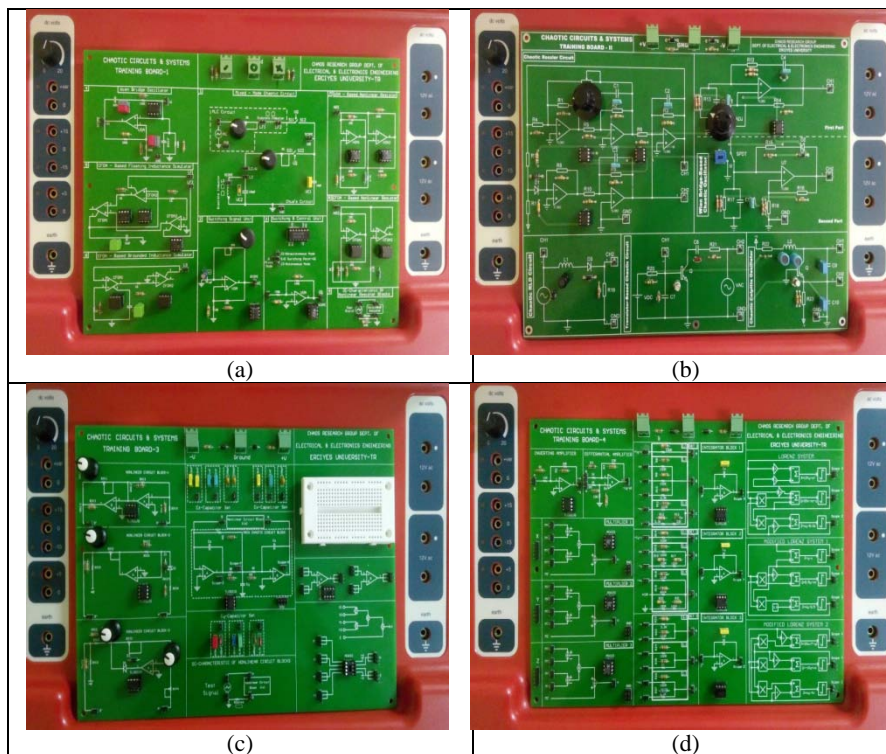

Fig. 1. Chaos Training Boards; (a)Board-I, (b)Board-II, (c) Board-III, (d)Board-IV.

In this study, it is aimed to introduce these Chaotic Training Boards with sample experiments. In section 2, the structures of the boards and design methodologies are given. Experimental studies with the proposed boards are summarized in section 3. Concluding remarks are discussed in the last section.

2 Chaos Training Boards: Design Methodology and the Hardware Structures

In this section, design methodology and the hardware structures of Chaos Training Boards are presented in detail.

A. Chaos Training Board-I

Chaos training board-I in Fig.1a consists of eight pre-constructed circuit blocks. The numbered blocks on training board are labeled as follow:

1. Mixed-Mode Chaotic Circuit (MMCC) Part
2. Switching Signal Unit-A Square wave generator
3. Switching &Control Unit
4. Wien-Bridge Oscillator
5. Current Feedback Operational Amplifier (CFOA)-Based Floating Inductance Simulator
6. Current Feedback Operational Amplifier (CFOA)-Based Grounded Inductance Simulator
7. Voltage mode Operational Amplifier (VOA)-Based Nonlinear Resistor
8. CFOA-Based Nonlinear Resistor

The core of training board-I is Mixed-Mode Chaotic Circuit (MMCC) [3] block shown in Fig.2a. MMCC Circuit operates either in the chaotic regime determined by autonomous circuit part, or in the chaotic regime determined by nonautonomous circuit part depending on static switching, and it is capable to operate in mixed-mode which includes both autonomous and nonautonomous regimes depending on dynamic switching. The autonomous chaotic oscillator is Chua's Circuit, and it is defined by Eq.1 [12]. The nonautonomous chaotic oscillator is MLC Circuit and it is defined by Eq.2 [13]. Because of having these

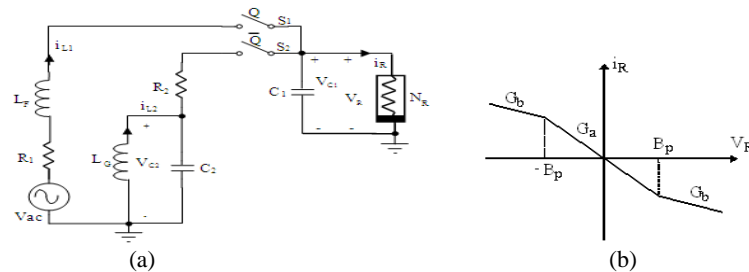

Fig. 2. a) MMCC circuit, b) $i-v$ characteristic of nonlinear resistor in MMCC circuit.

versatile features, MMCC circuit offers an excellent educational circuit model for studying and practical experimenting chaos and chaotic dynamics.

$$\begin{aligned}
C_1 \frac{dv_{C1}}{dt} &= \frac{(v_{C2} - v_{C1})}{R} - f(v_{C1}) \\
C_2 \frac{dv_{C2}}{dt} &= \frac{(v_{C1} - v_{C2})}{R} + i_L \\
L \frac{di_L}{dt} &= -v_{C2} - i_L R_s
\end{aligned} \tag{1}$$

$$\begin{aligned}
C \frac{dv_c}{dt} &= i_L - f(v_R) \\
L \frac{di_L}{dt} &= -R_1 i_L - i_L R_s - v_R + A \sin(\omega t)
\end{aligned} \tag{2}$$

As a result of being very flexible and versatile design methodology of training board, the user can configure the main chaotic circuit block in two forms: First, the user can configure the circuit as conventional way by placing discrete inductor elements to related sockets in the training board. And as an alternative way, the user can configure the chaotic circuit in inductorless form by using CFOA-based grounded and floating inductance simulators and Wien-Bridge Oscillator block located to the left side of the board. In this inductorless configuration, the user can also use Wien-Bridge oscillator block instead of LC resonator part on training board.

B. Chaos Training Board-II

Chaos Training Board-II consists of five pre-constructed chaotic circuit blocks. The numbered blocks on training board are labeled as follow: Chaotic Rössler Circuit, Chaotic Wien Bridge Oscillator, Chaotic RLD Circuit, Transistor-based Nonautonomous Chaotic oscillator, Chaotic Colpitts Oscillator.

Chaotic Rössler Circuit is introduced by Otto Rössler, in 1976 [14]. This system is defined by Eq.3. Different electronic circuit implementations of the Rössler system are available in the literature [15, 16]. Circuit configuration used in Chaos Training Board-II of Rössler system is shown in Fig.3a.

$$\begin{aligned}
\dot{x} &= -\alpha(\Gamma x + \beta y + \lambda z) \\
\dot{y} &= -\alpha(-x - \gamma y + 0.002z) \quad g(x) = \begin{cases} 0, & x \leq 3 \\ \mu(x-3), & x > 3 \end{cases} \\
\dot{z} &= -\alpha(-g(x) + z)
\end{aligned} \tag{3}$$

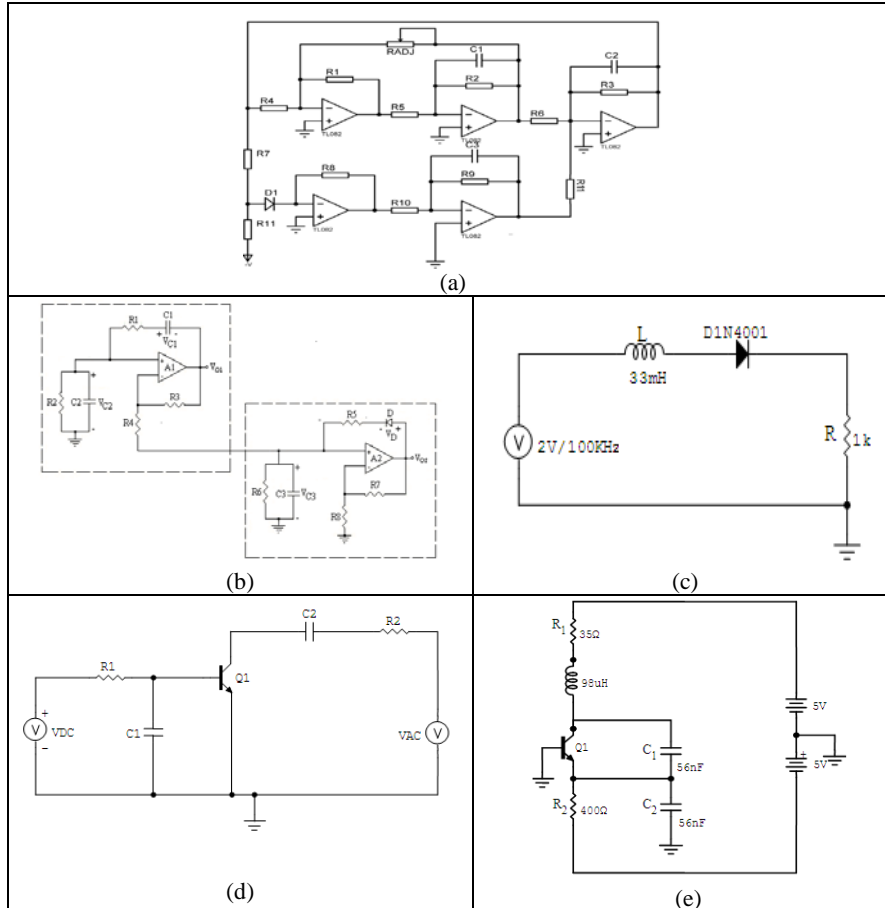

Fig. 3. Chaotic circuits in Chaos Training Board-II; a) Chaotic Rössler Circuit, b) Chaotic Wien Bridge Oscillator, c) Chaotic RLD Circuit, d) Transistor-based Nonautonomous Chaotic oscillator, e) Chaotic Colpitts Oscillator.

The second example on the board is Chaotic Wien-Bridge oscillator [17] shown in Fig.3b. This chaos generator is formed by two circuit blocks using VOAs as active elements as shown in Fig. 3b. The first block is a Wien bridge oscillator with the gain $K_1 = 1 + \frac{R_3}{R_4}$ and the second block plays the role of a Negative

Impedance Converter (NIC). In this design, by including a diode in the positive feedback loop of A2, the NIC is only activated that case $V_{C3}(K_2 - 1) > V_D$ where

$$K_2 = \left(1 + \frac{R_7}{R_8}\right) \text{ is the gain of A2 and } V_D \text{ is forward voltage drop of the diode.}$$

The third example on the board is a nonautonomous chaotic circuit referred to as RLD chaotic circuit [18]. As shown in Fig.3c, RLD circuit consists of an AC voltage source, a linear resistor, a linear inductor and a diode which provides the nonlinearity in the circuit. One can observe in this circuit that the current can be chaotic while the input AC-voltage is a linear oscillator.

The fourth example on the training board-II, shown in Fig.3d, is the transistor-based nonautonomous chaotic circuit [19] coupling of an oscillator and a transistor. This is very useful example show that a coupling mechanism, which consists of two electronic circuits are not in harmony, can exhibit chaotic dynamics. The mechanism behind this circuit is based on a capacitor charging process by means of “forward-reverse fighting” of the transistor.

The last chaotic circuit example on the training board-II, shown in Fig. 3e, is the chaotic Colpitts oscillator [5]. Undergraduate students are familiar with this oscillator circuit and this circuit is introduced as a sinusoidal oscillator circuit in analog electronic courses, but yet it can be driven to chaos. In a classical Colpitts oscillator circuit, transistor plays the role of both the active amplifying device and nonlinear element. So, the sinusoidal oscillator circuit in Fig. 3e is able to exhibit nonlinear chaotic dynamics according to the certain parameter setting in the circuit structure.

C. Chaos Training Board-III

Chaos Training Board-III is based on the “Jerk equations”. Jerk equation is defined by a third-order ordinary differential equation as follow:

$$\ddot{v} + A\dot{v} + \dot{v} = F(v) \quad (4)$$

where A is a constant parameter and F(v) is a nonlinear function. This nonlinear function affects the behavior of the system and it has different mathematical descriptions as in Table 1 [7].

Table 1. Nonlinear functions of Jerk Equation.

Nonlinear Functions F(v)	Parameters of F(v)
$f(v) = -Bv + C \operatorname{sgn}(v)$	$B=1.2, C=2$
$f(v) = -B \max(v,0) + C$	$B=6, C=0.5$
$f(v) = v - r$	$r=2,$
$f(v) = B(v^2 / C + C)$	$B=0.58, C=1$
$f(v) = Bv(v^2 / C - 1)$	$B=1.6, C=5$
$f(v) = -Bv(v^2 / C - 1)$	$B=0.9, C=0$
$f(v) = -B[v - 2 \tanh(Cv) / C]$	$B=2.15, C=1$

These nonlinear functions have been implemented by using discrete circuit elements. A main circuit block was constructed for Jerk equation and then each of the nonlinear function circuits was coupled with this main circuit block respectively. After the studies of Sprott [7], it has been improved these chaotic circuits. For example, FTFN (Four Terminal Floating Nullor)-based circuit topologies are constructed. By using different capacitor values in FTFN-based circuit, the high frequency performance of Sprott's chaotic circuits have been verified experimentally in [8]. Chaos Training Board-III is built on Jerk equation; it consists of five basic blocks about Sprott's circuit as seen in Fig.1c. These blocks are listed as follow: Main Chaotic Circuit Block, Nonlinear Circuit Blocks, DC characteristic of nonlinear circuit blocks, Capacitor sets and Training area.

The main circuit block defined by Eq.4 is common to all Sprott's circuits. This block is positioned in the middle of the board as seen in Fig.1c. On the board, there are three different nonlinear circuit blocks on the left side of the main circuit. While the main circuit block is presented in Fig.4a, the circuit schemes of three nonlinear functions in Table 1, namely nonlinear function blocks, are illustrated in Fig.4b.

To observe the dc characteristic of the nonlinear function, a simple block has been added to the bottom of the main circuit. Three capacitor sets are located the

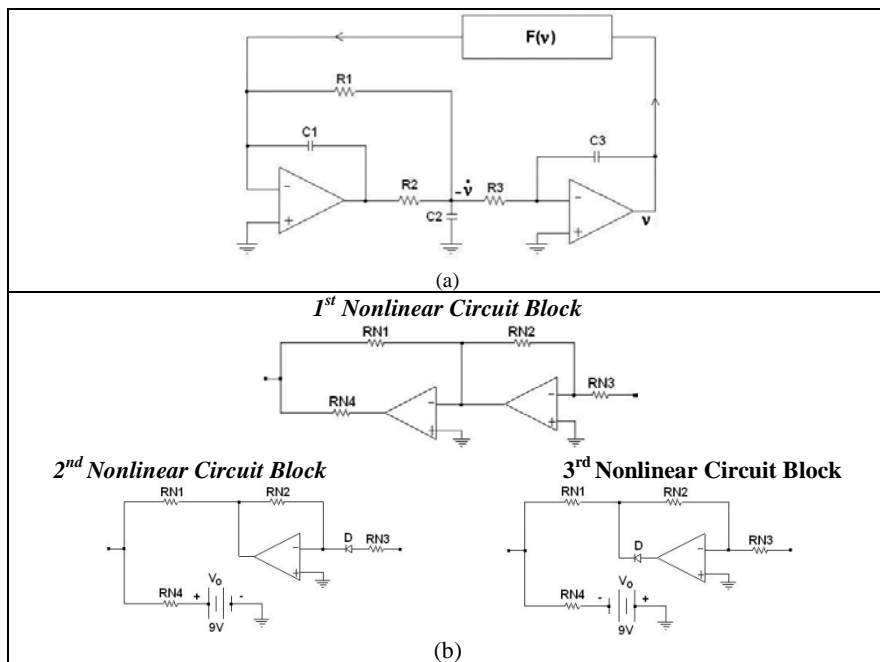

Fig.4. Simple chaotic circuit proposed in [7] and the circuit blocks of nonlinear functions.

around the main circuit block as seen in Fig.1c to obtain chaotic circuits having different frequency ranges. On the right side of the board, a training area is located for configuring different nonlinear circuit blocks by the user.

D. Chaos Training Board-IV

Circuit implementations of three chaotic systems, which belong to the General Lorenz System Family, are objected in the Chaos Training Board-IV as shown in Fig.1d. The General Lorenz System Family is defined by following equations [11]:

$$\begin{aligned}\dot{x} &= a_1x + a_2y + a_{13}xz + a_{23}yz \\ \dot{y} &= b_1x + b_2y + b_{13}xz + b_{23}yz + d_2 \\ \dot{z} &= c_3z + c_{13}xy + c_{11}x^2z + c_{22}y^2 + c_{33}z^2 + d_3\end{aligned}\quad (5)$$

After some simplifications and parameter adjustments, this general system is called with different systems. Table 2 summarize these systems and their parameter values. Three different systems in Table 2 can be implemented by using Chaos Training Board-IV. First of them is Lorenz System, because it is

Table 2: General Lorenz System Family equations and parameter values.

General Lorenz System Family	Equations	Parameters
Lorenz System	$\dot{x} = a(y - x)$ $\dot{y} = cx - xz - y$ $\dot{z} = xy - bz$	a=10 b=8/3 c=28
Chen System	$\dot{x} = a(y - x)$ $\dot{y} = (c - a)x - xz - cy$ $\dot{z} = xy - bz$	a=35 b=3 c=28
Lü System	$\dot{x} = a(y - x)$ $\dot{y} = -xz + cy$ $\dot{z} = xy - bz$	a=36 b=3 c=20
Lorenz-like system	$\dot{x} = -((ab)/(a + b))x - yz + c$ $\dot{y} = ay + xz$ $\dot{z} = bz + xy$	a=10 b=4 c=8
Modified Lorenz System	$\dot{x} = y - x$ $\dot{y} = ay - xz$ $\dot{z} = xy - b$	a=0.5 b=0.5 c=0

CHAOTIC CIRCUITS & SYSTEMS TRAINING BOARD -4 ERCİYES UNIVERSITY-TR		POWER SUPPLY		CHAOS RESEARCH GROUP DEPT. OF ELECTRICAL & ELECTRONIC ENGINEERING
INVERTING AMPL.	DIFF. AMPL.	ADDER-I (LORENZ SYSTEM)	INTEGR. BLOCK-I (X)	LORENZ SYSTEM DESCRIPTION
X	MULTIPLIER-I	ADDER-II (MODIFIED LORENZ SYSTEM)	INTEGR. BLOCK-II (Y)	MODIFIED LORENZ SYSTEM DESCRIPTION
Y	MULTIPLIER-II			
Z	MULTIPLIER-III	ADDER-I (LORENZ-LIKE SYSTEM)	INTEGR. BLOCK-III (Z)	LORENZ-LIKE SYSTEM DESCRIPTION

Fig 5. Schematic demonstration of Chaos Training Boards-IV.

the basic structure of General Lorenz System Family. To have a simple mathematical definition, Modified Lorenz System is selected as second circuit. On the other hand, Lorenz- Like system has the most multiplication operations, namely it has the most complex definition and last circuit is Lorenz-Like system on this training board.

Although chaotic systems in Table 2 have different behaviors, their mathematical equations are very similar to each other. Chaos Training Board-IV is designed by utilizing these similarities and it has some common blocks for mentioned three general Lorenz-based systems. These system blocks consist of Inverting amplifier block, Differential amplifier block, Multipliers, Adder blocks, Integrator blocks and System identification blocks as seen in Fig.5.

The operations of the blocks on the training board-IV can be summarized as follow:

- To implement $(y - x)$ operations, a differential amplifier,
- To implement $-x$ or $-y$ operations, an inverting amplifier,
- To implement xz , xy , yz or their negative, three multiplier circuits,
- To implement addition or subtraction operations, several resistors in various values,
- To implement \dot{x} , \dot{y} or \dot{z} operations, three integrator blocks,

have been used on the Chaos Training Board-IV. By using system identification blocks about chosen three systems, the connections between operation blocks can be made easily. Finally, three different systems in Table 2 can be implemented with this board by using essential blocks.

3 Experimental Studies with the Training Boards

Chaos Training Boards are introduced in previous sections. Some of the observed experimental results by using these training boards are presented in the following section.

A. Experimental Results of Chaos Training Board-I

By applying the jumper adjustments, the users can easily realize laboratory experiments on relevant chaotic circuits on Chaos Training Board-I. After the autonomous Chua's circuit [12] configuration is obtained, the user can investigate the autonomous chaotic dynamics. The experimental observations for autonomous mode of the board have been illustrated in Fig.6a. These results illustrate chaotic time series of voltage across of C1 and C2 in MMCC circuit and chaotic attractor measured in VC1-VC2 plane.

The user can investigate chaotic dynamics of MLC circuit by making the necessary arrangements on the training board-I. VAC sinusoidal signal required for this nonautonomous system is taken from sine-wave output of an external function generator. Its amplitude and frequency are determined as $V_{rms}=100mV$ and $f=8890Hz$, respectively. By adjusting amplitude of the AC signal source and/or R1 potentiometer located in nonautonomous part of MMCC circuit, the user can easily observe the complex dynamics of bifurcation and chaos phenomenon. Some experimental observations for this nonautonomous mode of the board have been illustrated in Fig.6b.

Mixed-mode chaotic phenomenon which includes both autonomous and nonautonomous chaotic dynamics can be observed via training board-I. In this mode switching time which determines the durations of autonomous and nonautonomous chaotic oscillations can be easily adjusted via R3 potentiometer located in square-wave generator block on the board. By adjustments of R1 and R2 potentiometers in MMCC circuit, a variety of mixed-mode chaotic dynamics are observed. Some experimental observations for this mixed-mode of the board have been illustrated in Fig.6c.

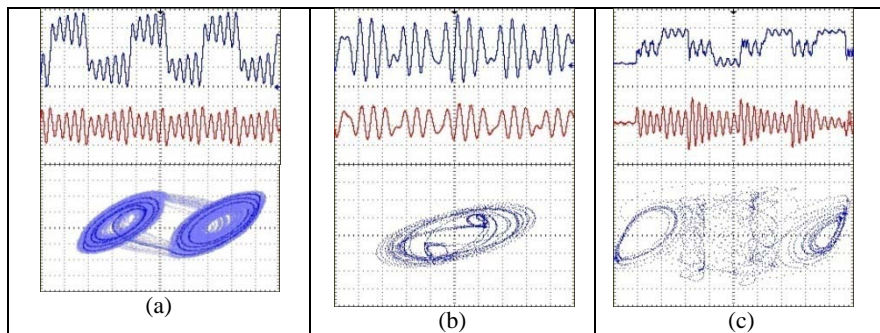

Fig 6. Experimental measurements of MMCC circuit on the board-I; a) with the autonomous mode configuration, b) with the nonautonomous mode configuration, c) with the mixed-mode configuration.

B. Experimental Results of Chaos Training Board-II

Since all chaotic circuit models on the training board-II are mounted to board as pre-constructed circuit blocks, laboratory experiments related to these circuits are easily made by using virtual measurement system. Fig. 7a shows measurements on chaotic Rössler circuit. This figure includes time domain illustration and chaotic attractor for V_{C2} and V_{C3} .

In Wien bridge-based chaotic circuit model, there are two oscillation modes for investigations. By configuring J1 jumper adjustment on the board-II, a classical linear Wien-bridge oscillator configuration is obtained. By configuring J2 jumper adjustment on the board-II, a nonlinear circuit block is coupled to classical linear Wien-bridge oscillator configuration and this nonlinear oscillator oscillates chaotically. Fig.7b shows measurement results illustrating the chaotic phenomena.

A VAC sinusoidal signal source must be used to observe the results of RLD circuit. Its amplitude and frequency are determined as $V_p=2V$ and $f=100kHz$, respectively. The recorded experimental measurements on the board-II for chaotic RLD circuit are given in Fig.7c.

By varying the amplitude of the oscillator, some interesting complex dynamic series from periodic behaviors to chaotic behavior can be observed via transistor-based chaotic circuit model. Fig.7d shows measurement results illustrating its chaotic phenomena.

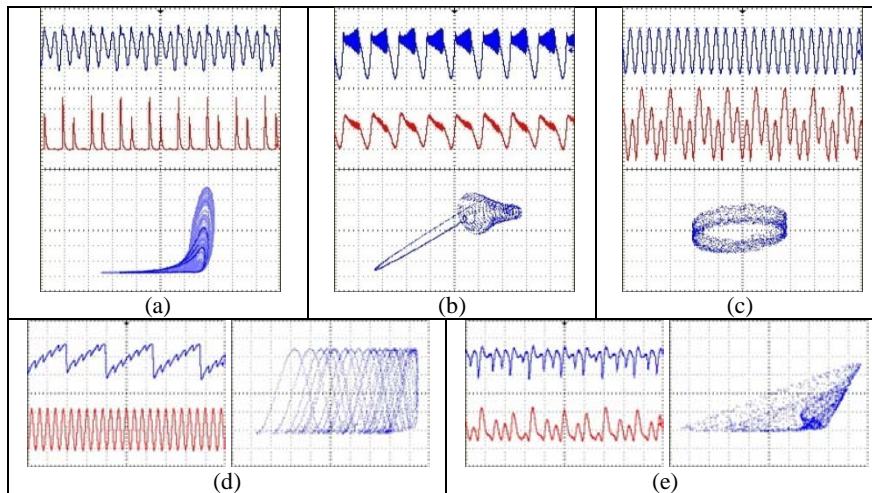

Fig 7. Experimental measurements of circuits on the board-II.

Fig.7e shows measurements on Colpitts oscillator. These results illustrate the time series of voltage across of C1 and C2 in Colpitts oscillator circuit, and chaotic attractor measured in VC1-VC2 plane. The parameters of Colpitts oscillator have been determined that the circuit oscillates in chaos mode.

C. Experimental Results of Chaos Training Board-III

In these experiments, nonlinear circuit blocks in Fig.4b are connected to the main circuit block respectively. While the phase portrait illustrations of Sprott's circuits based these systems are seen in Fig.8a, dc characteristics of nonlinear circuit blocks are presented in Fig.8b.

As mentioned in previous section , there are three capacitor set blocks on Chaos Training Boards-III and these blocks provide chaotic signals in variable frequencies. For third nonlinear circuit block in Fig.4b, time domain illustrations in different frequency are given in Fig.9. In addition to these properties, there are several potentiometers on the nonlinear circuit blocks as seen in Fig.1c. By changing their values, the user can easily observe the complex dynamics of bifurcation and chaos phenomenon clearly.

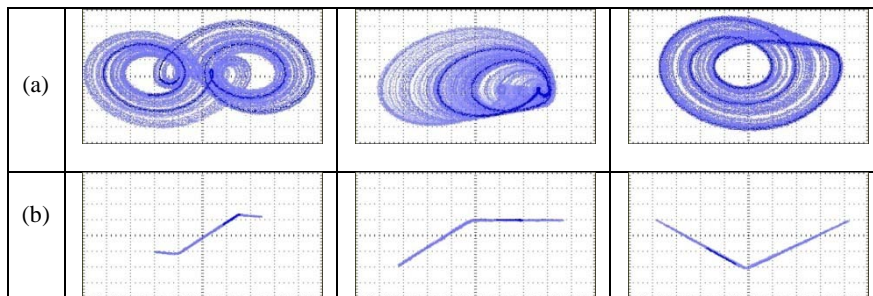

Fig.8. Experimental results for the Chaos Training Board-III: a) The phase portrait illustrations of Sprott's chaotic circuits, b) DC characteristics of the nonlinear circuit blocks.

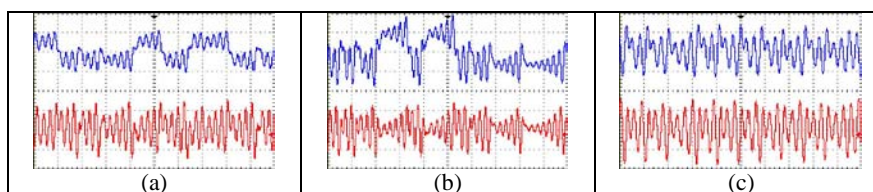

Fig.9. Time domain responses of third nonlinear circuit block in different frequency, x: 2 V/div, y: 0.2 V/div a) time: 2.5 ms/div, b) time: 250 μ s/div, c) time: 25 μ s/div.

D. Experimental Results of Chaos Training Board-IV

In Chaos Training Boards-IV, three different chaotic systems, which are the members of general Lorenz System family, can be constructed by using common blocks via system identification blocks. The experimental results of these systems are given in Fig.10 respectively.

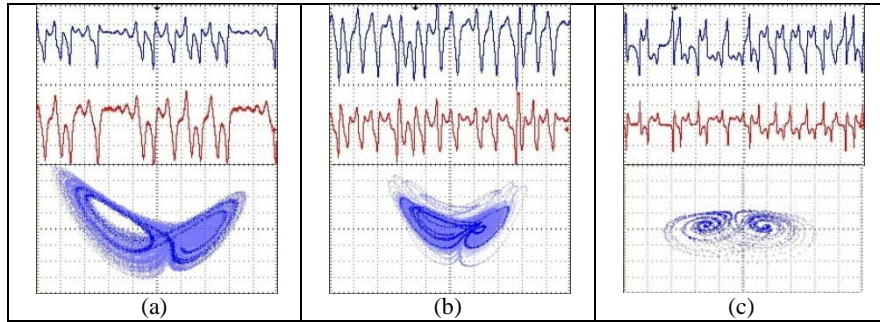

Fig.10. Experimental results of; a) Lorenz, b) Modified Lorenz, c) Lorenz-Like chaotic systems on Chaos Training Board-IV.

Conclusions

Chaos training boards have been introduced in this study with sample experimental studies. These experiments have been selected for demonstration of functionality and versatility of the boards. Chaos Training Board-I is based on the MMCC and thanks to its switching mechanism, it is capable to operate autonomous, nonautonomous and mixed-mode mode chaotic dynamics. The circuits on the Chaos Training Board-II are selected for illustrating a variety of ways in which chaos can arise in simple analog oscillator structures containing active elements, specifically BJT and Op-amp. While the user has the possibility of examination for a Jerk equation based chaotic system with different nonlinear functions on Training Board-III, Lorenz family systems are easily configured and constructed in the Training Board-IV. A laboratory program arranged with the proposed chaos training boards can be easily accompanied with nonlinear courses in science and engineering programs. We hope this study will provide a practical guide for the readers and the boards presented here will be very useful laboratory apparatus for nonlinear studies in science and engineering research and education programs.

Acknowledgment

This work has been supported by “Office of Scientific Research Projects of Erciyes University” under FBA-11-3548 grant number.

References

1. R. Kılıç and B. Karauz. Chaos Training Boards: Versatile pedagogical tools for teaching chaotic circuits and systems. *International Journal of Engineering Education*. 25, 3, 634{644, 2008.
2. R. Kılıç, N. Korkmaz and E. Günay. An introductory study for chaos training board series. The 21th Workshop on Nonlinear Dynamics of Electronic Systems-NDES 2013, Bari, Italy, 2013.
3. R. Kılıç, M. Alçı and M. Tokmakçı. Mixed-Mode chaotic circuit. *Electronics Letters*. 36, 103{104, 2000.
4. R. Kılıç. Experimental study of CFOA-based inductorless Chua's circuit, *International Journal of Bifurcation and Chaos*. 14, 1369{1374, 2004.
5. M.P. Kennedy. Chaos in the Colpitts oscillator. *IEEE Trans. Circuits Systems-I*. 41, 771{774, 1994.
6. A. S. Elwakil and A. M., Soliman. A family of Wien type oscillators modified for chaos. *Int. J. Circuit Theory Appl*. 25, 561{579, 1997.
7. J.C. Sprott. Simple chaotic systems and circuits. *Am. J. Phys*, 68, 8, 758{763, 2000.
8. F.Y. Dalkiran, E. Uzunhisarcikli, R. Kiliç and M. Alçi. Experimental verification of high frequency performance of FTFN-based simple chaotic circuit. *International Journal of Bifurcation and Chaos*. 15, 191{205, 2005.
9. E.N. Lorenz. Deterministic nonperiodic flow. *J. Atmos. Sci*. 20, 130{141, 1963.
10. A.Vanecek and S. Celikovsky. Control systems: From linear analysis to synthesis of chaos. London: Prentice-Hall, 1996.
11. İ. Pehlivan and Y. Uyaroglu. A new chaotic attractor from general Lorenz system family and its electronic experimental implementation. *Turk J. Elec. Eng. & Comp. Sci*. 18, 2, 171{184, 2010.
12. L.O. Chua, C.W. Wuand, A. Huang and G. Zhong. A universal circuit for studying and generating chaos-part I: Routes to chaos. *IEEE Trans. Circuits &Systems-I*. 40, 732{761, 1993.
13. K. Murali, M. Lakshmanan and L.O. Chua. Bifurcation and chaos in the simplest dissipative nonautonomous circuit. *International J. of Bifurcation &Chaos*. 4, 1511{1524, 1994.
14. O.E. Röessler. An equation for continuous chaos. *Physics Letters*, 57, 5: 397{398, 1976.
15. T.L. Carroll. A simple circuit for demonstrating regular and synchronized chaos. *American Journal of Physics*. 63, 4, 377{379, 1995.
16. T. Yoshinaga, H. Kitajima and H. Kawakami. Bifurcation in a coupled Röessler system. *IEICE Trans. Fundamentals*. 78, 10, 1276{1280, 1995.
17. A.Namajunas and A. Tamasevicius, Modified Wien bridge oscillator for chaos, *Electronics Letters*, 31, 335{336, 1995.
18. P. Linsay. Period doubling and chaotic behaviour in a driven inharmonic oscillator. *Phys. Rev. Lett*. 47, 1349{1392, 1981.
19. E. Lindberg, A. Tamasevicius and K. Murali., The Smallest Transistor-Based Nonautonomous Chaotic Circuit, *IEEE Trans. on Circuit and Systems II*, 52, 10, 661{664, 2005.